

Level 7 means that I can...

- Round to one significant figure

Round off to 1 significant figure:

a. 21	b. 345.7
c. 0.54	d. 0.55
e. 99	f. 0.0127

- Understand what happens when we multiply or divide by numbers between 0 and 1

If you multiply and divide 5 by the following numbers. What is happening to the size of the answers?					
5	X 1 =		5	÷ 1 =	
5	X 0.9 =		5	÷ 0.9 =	
5	X 0.8 =		5	÷ 0.8 =	
5	X 0.7 =		5	÷ 0.7 =	
5	X 0.6 =		5	÷ 0.6 =	
5	X 0.5 =		5	÷ 0.5 =	
5	X 0.4 =		5	÷ 0.4 =	
5	X 0.3 =		5	÷ 0.3 =	
5	X 0.2 =		5	÷ 0.2 =	

5	$\times 0.1 =$		5	$\div 0.1 =$	
5	$\times 0.09 =$		5	$\div 0.09 =$	
5	$\times 0.08 =$		5	$\div 0.08 =$	
5	$\times 0.07 =$		5	$\div 0.07 =$	
5	$\times 0.06 =$		5	$\div 0.06 =$	
5	$\times 0.05 =$		5	$\div 0.05 =$	
5	$\times 0.04 =$		5	$\div 0.04 =$	
5	$\times 0.03 =$		5	$\div 0.03 =$	
5	$\times 0.02 =$		5	$\div 0.02 =$	
5	$\times 0.01 =$		5	$\div 0.01 =$	
5	$\times 0 =$		5	$\div 0.009 =$	

Multiply and divide numbers of any size

Workout the following:			
1.	46×32	5.	$156 \div 13$
2.	0.72×3	6.	$12.4 \div 4$
3.	4.2×0.6	7.	$17.5 \div 0.5$
4.	0.3×0.2	8.	$0.72 \div 0.008$

- Understand proportional change

If h is directly proportional to k , find the missing values:

h	2	5		12		60	100
k	12	30	72		15		

If r is inversely proportional to s , find the missing values:

r	2	5		2.5		50	100
s	5		20		15		

- Describe in symbols the rule for the next term or n^{th} term in a sequence (Quadratic)

Describe the term-to-term rule and the position rule for the n^{th} term rule

n	1	2	3	4	5	6	7
Term	3	7	13	21	31	43	57

□ Multiply things like $(a+b)(c+d)$

Expand the brackets in the following:

1. $(x + 3)(x + 2)$ 2. $(x + 3)(x - 2)$

3. $(x - 3)(x + 2)$ 4. $(x - 3)(x - 2)$

□ Simplify quadratic expressions

Simplify the following:

1. $x^2 + 3x + 2x + 6$

2. $x^2 + 3x - 2x - 6$

3. $x^2 - 3x - 2x - 6$

4. $x^2 - 3x - 2x + 6$

□ Solve simultaneous, linear equations with two variables (Using graphs or algebra)

1. Using graphs, solve:

a. $y = x + 4$
 $y = 2x$

c. $2x + 2y = 10$
 $3x - y = 7$

b. $y = 4 - x$
 $y = 2x - 5$

d. $2y + 3x = 24$
 $y - x = 2$

2. Using algebra, solve:

a. $y + x = 10$
 $y - x = 2$

c. $5x - 2y = 20$
 $3x + y = 23$

b. $3y - 2x = 10$
 $2y - 2x = 4$

d. $4x + 2y = 22$
 $3y + 6x = 39$

□ Solve inequalities like $6(2n+1) \geq 18$

Solve:

a. $4x + 3 \geq 11$

b. $3x + 2 \leq x + 12$

c. $2(x - 3) \geq x + 6$

d. $4(x - 3) \geq 3(x + 6)$

△

□ Understand and use Pythagoras' Theorem in 2D

Calculate the unknown sides in the following triangles:

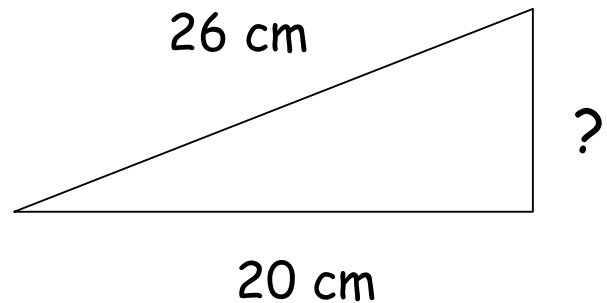
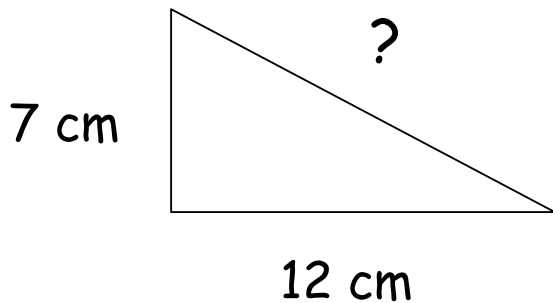

- Understand similarity

The two triangles below are similar. Calculate the lengths X and Y .

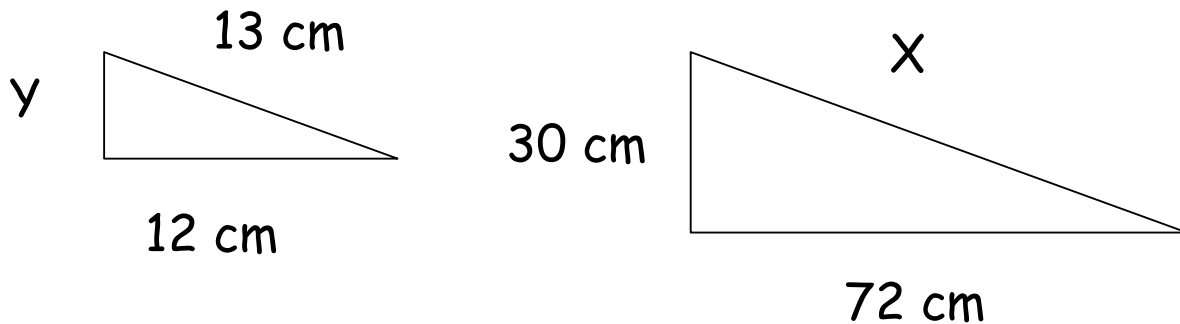

- Draw the locus of a moving object

- Find and understand upper and lower bounds
- Use compound measures like speed, distance, time

1. A train travels at 120 mph for 1 hour and 12 minutes . How far has the train travelled?

2. A boy walks 10 miles in 2 hours 30 minutes. What is his average speed?
3. How long will it take to travel 7 miles at a speed of 16 mph?

- Give and test a hypothesis to a situation
- Understand bias
- Find the modal class and an estimate to the mean, median and range when using grouped data

Find the modal class and an estimate of the mean for the information about the amounts of money spent going shopping shown in the table below

Money	Frequency
0 - 10	3
10 - 20	7
20 - 30	12
30 - 40	14
40 - 50	4

- Compare distributions using frequency polygons

The amount money spent a Saturday shopping trip is shown below for teenagers in different age groups. Put this information onto a frequency polygon and comment on the results.

Money	13 - 16 Freq	17 - 20 Freq
0 - 10	8	3
10 - 20	10	5
20 - 30	12	13
30 - 40	14	16
40 - 50	4	10

- Draw a line of best fit on a scatter diagram

- Understand relative frequency